

### 1 Introduction:

CMD200 is an intelligent charger for engine, is used for engine starting, telecom base stations and power back-up power supply which used lead-acid batteries and nickel-cadmium batteries charging to design, the professional design makes it suitable for all kinds of harsh environments. Feature:

- I Microprocessor control measure
- I Digital display battery voltage and charging current
- I Battery temperature compensation (optional)
- I Compatible with 12 / 24V battery, panel microswitch selection
- I 3 stage charging
- I High efficiency of switch power supply circuit
- I Precision die-cast aluminum case, compact appearance
- I Fanless design, natural air-cooled
- I Perfect protection function: battery high and low voltage, overcurrent, high temperature, reverse polarity protection and so on.

### 2 Shape and installation dimensions:

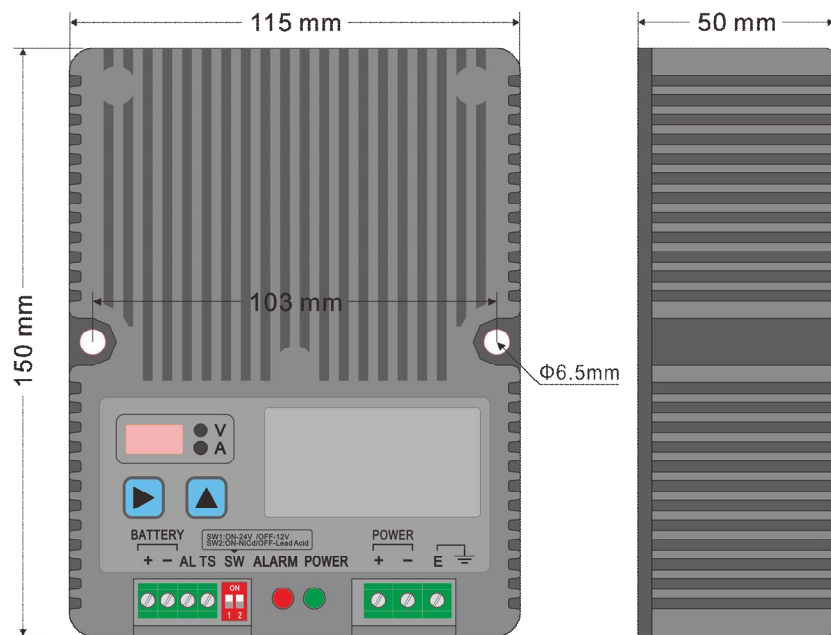

### 3 Typical wiring diagram:

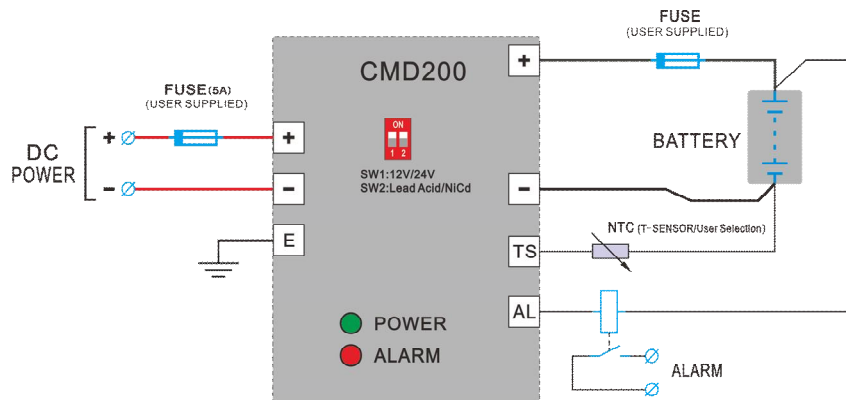

#### 4 Auto charging process

According to the features of the battery charging to design, the charger have 3 stage charging method, charging process as follows:

Phase 1 (constant current): charger at a constant current for the battery, at this stage the battery voltage is gradually increased, when the battery voltage reaches  $V_{boost}$  voltage, the charger into the charging phase 2.

Phase 2 (constant pressure) : charger at a onstant voltage  $V_{boost}$  (Fast charge voltage) for the battery, the charging current at this stage will gradually decline, when the charge current drops to 15% of rated current, the charger into the charging phase 3.

Phase 3 (float): charger at a constant voltage  $V_{float}$  (Float voltage) for the battery. Float process, the charging current is generally less for maintaining the battery fully charged.

**Charge graph:**

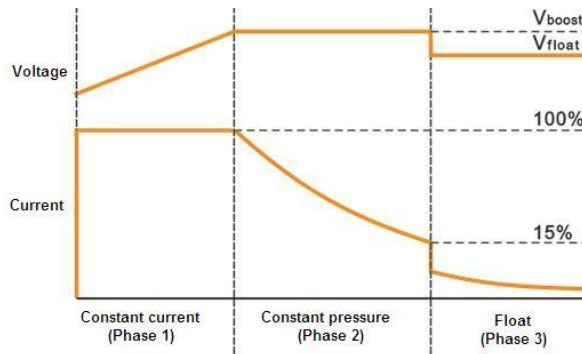

#### 5 LED indicating lamp

**POWER:** When connected to the DC power, and in the normal range, the indicator illuminate.

**ALARM:** When the charging failure occurs, the LED flashes. According shiny frequencies representing different fault.

#### 6 Protection function (reverse polarity protection, high-voltage, over-current, high temperature):

**Reverse polarity protection:** When the battery charger output port positive and negative reverse polarity, output fault effectively, fault indicator light flashes once every 3 seconds, such cycle. Charge stop.

**High and low voltage:** When the battery voltage is detected to be higher than the high limit voltage, the fault output is effectively, when continuous fault indicator flashes twice and stopped 3 seconds, charge stoped. When the battery voltage is lower than the lower limit, the fault output is valid, the fault indicator flashes 5 times every 3 seconds, the charging does not stop.

**Overcurrent fault:** When the detected charge current is greater than the limit current, the fault output is effectively, fault indicator continuous flashes 3 times, and stopped 3 seconds, then continuous flashes three times, such cycle. Charge stop.

**High temperature fault:** when detecting the charger internal temperature is higher than the built-in protection value (95 °C), duration of 30 seconds, high-temperature failure, the fault output is effectively, fault indicator continuous flashes 4 times, and stopped 3 seconds, then continuous flashes 4 times, such cycle. Charge stop.

#### 7 Electrical Specifications

Selector witch (SW2)	Lead Acid	NiCd
Vboost	14.0V / 28.0V	14.5V / 29.0V
Vfloat	13.6V / 27.2V	14.1V / 28.2V
Rated output current	10A (12V) / 8A (24V)	
Enter into the DC voltage	40 to 60VDC	
Maximum output power	200W	
Operating temperature range	-30 to 55°C	
Storage temperature range	-40 to 80°C	